

# Maestro 16

DISTRIBUTED MACHINE CONTROLLER



Coordinates Very High Speed Machinery, Including: Sensors, Encoders, Actuators, PLCs, Computers, Cameras and Illuminators

*Opteon's Maestro is a distributed network controller which is far faster and easier to program than conventional Programmable Logic Controllers. It overcomes the three challenges of modern machine building:*

## Remote Signaling

Cabling density rises exponentially with machine complexity. Each cable costs money, is a point of failure, delays communication, and is an antenna for any noise in the system frequently resulting in spurious or missing triggers. In an Opteon PoE GigE system, there are no power cables and the Cat 5e or Cat 6 communication cable is shielded so there are no emissions. All communications are encoded with CRC checks and are always acknowledged by receivers so even in the noisiest of environments nothing is ever lost or missed.

## Host Communication and Synchronization

The Maestro Controller within an Opteon equipped machine unifies the concepts of time and position among dissimilar equipment. Each communication includes the reason and global time of each action so that decisions can be taken in non-realtime portions of a system, yet their implications realized in the realtime portions of the system at precisely the right time and conditions.

## Parts Tracking

Deep, parallel hardware structures implemented in Opteon controllers are matched with language elements that closely match the tasks required for tracking parts through multi-lane, multi-stage, processing and inspection. Systems can be quickly described that may include any number of synchronous and asynchronous components. Time and machine-motion are managed seamlessly, regardless of the sign or magnitude of the numbers involved so that the resulting program will allow the Maestro to continue to coordinate flawlessly at any speed or even in cases where the machine can be halted or reversed.

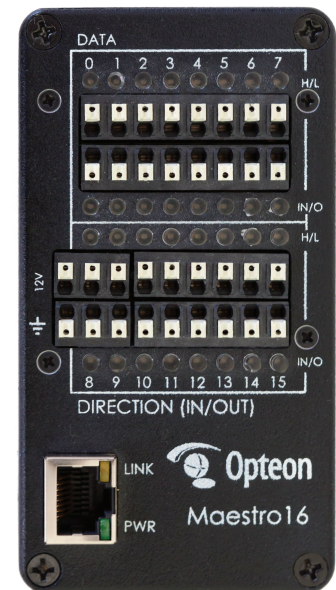

## Product Highlights

- 16 Bidirectional, Opto-Isolated channels
- Integrated programmable logic controller with 1  $\mu$ s Scan Time eliminates latencies to stop action to sub-pixel precision
- Parts and web tracking through very large systems composed of hundreds of parts and dozens of stations
- No trigger or strobe cables required
- CRC checks and handshaking guarantee noise immunity and reliability

## Opteon Corporation

1 Mifflin Place • 119 Mt Auburn St, Suite 400 • Cambridge, MA 02138  
Phone: 617.520.6658 • Fax: 617.674.7701 • E-mail: info@opteontech.com

[opteontech.com](http://opteontech.com)

## General Specifications

### Power

Supply Voltage	22 - 30 VDC
or via I.E.E.E. 302.af Power Over Ethernet, PoE	42 - 56 VDC
Supply Current (24 VDC)	115 mA

### Environmental Specifications

Acceleration	15 G
Shock	70 G
Thermal operating range ( <i>Case</i> )	-30 to 50 °C
Thermal storage range ( <i>Ambient</i> )	-60 to 85 °C
Humidity	0 - 95% NC
Weight	200 gm

### Interfaces

Ethernet ( <i>Automatic PoE Negotiation, Local Voltage Priority</i> )	1000BaseT
BiDirectional, Opto-Isolated Digital I/O	16
Input Response	10 Mhz
Input Voltage, Minimum - Maximum	5-30VDC
Output Response	50 KHz
Output Response with High Speed Outputs Option	10 Mhz
Output Load, maximum	40VDC
Output current, sinking, maximum	75mAmp
Integrated Programmable Logic Controller, 1 uS Scan	0 or 1

## Physical Dimensions

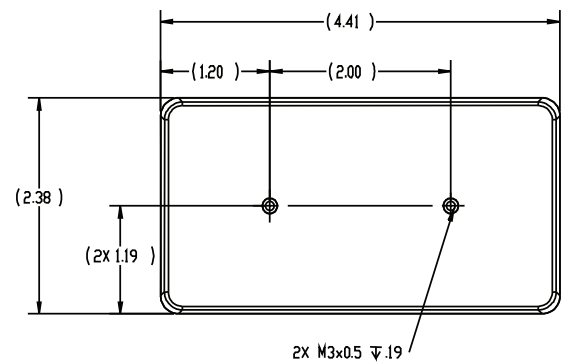
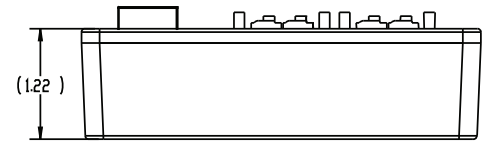
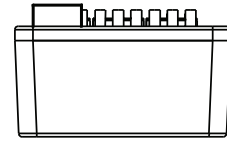

## Opteon Corporation

1 Mifflin Place • 119 Mt Auburn St, Suite 400 • Cambridge, MA 02138  
Phone: 617.520.6658 • Fax: 617.674.7701 • E-mail: info@opteontech.com